

# Microsync Series

Micro Inverter  
STMSI-800/1600



# About

Servotech is dedicated to creating value through transformative change, with a commitment to advancing a green future through sustainable development and relentless innovation. Our eco-friendly products are designed to lead the way in renewable energy and electric mobility. With an extensive presence spanning over two decades we have curated high value solutions.

Our green product portfolio features comprehensive solar solutions, including solar panels, inverters, and batteries. The Microsync Series Micro Inverter is a notable addition to our robust lineup of efficient solar products, reflecting our forward-thinking approach. Recognizing the importance of integrating cutting-edge technology, we have developed these advanced micro inverter. Servotech continues to push the boundaries of solar technology, ensuring we deliver superior performance and innovation to our customers.

## Solar, Simplified with Microsync Series

Servotech's Microsync Series with its new and improved advanced technology redefines the concept of renewable power. Crafted with sincerity, built on reliability, Microsync series is a reflection of Servotech's long lasting legacy of technology driven reliable and durable products.

### Here is why you should choose us:

- **Industry Leader:** As a pioneering solar solutions provider, Servotech leads innovation in the renewable energy sector, with products trusted by customers globally.
- **Precision Engineering:** Our micro inverter inverters are expertly crafted for efficient energy conversion, ensuring maximum power output from your solar panels.
- **High Efficiency:** Designed with a focus on optimal performance, Servotech inverters provide high energy conversion rates, lowering electricity costs and maximizing your solar investment.
- **User-Friendly Design:** Featuring easy-to-use interfaces and simple installation, our inverters offer a seamless experience, making solar power accessible and convenient for all households.

# Microsync Series

## 1 Driven 2 System



**Convenient multi-angle adjustment, aluminum alloy bracket**  
**Simply connect to your home Wi-Fi for remote management by phone**



**More Energy** Combine a micro-inverter with a high-quality panel with adjustable opening brackets to maximize power generation.



### Integration

The system integrates solar panels, inverters and cables. Portable and fold-able for a variety of applications.



### Safe and Simple

Plug and play connection, no professional installation team, more savings in installation costs.



### Quality Guaranteed

In line with the EU regional security certification, the system multiple protection



## Advantages

---

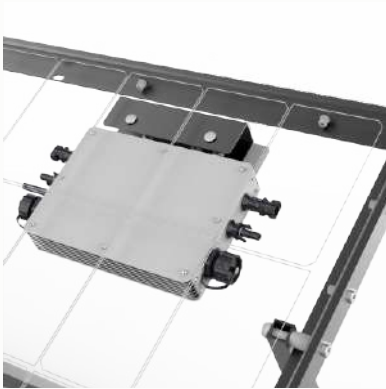

**Integrated Design  
(Included Inverter)**



**Plug and Play  
(For 110/220V)**



**Remote Monitoring  
(Sun Plus APP)**

## Configuration List

---



### Solar Panel with bracket\*2

- Good for packaging and shipment
- Aluminum alloy material
- Integrated design, easy assembling
- Multi-angle adjustment



### Micro Inverter STMSI-800

- Aluminum alloy material is durable
- Plug and play extended flexibility
- Separate MPPT improve the output power effectively
- Remote access to data in real time using Sun Plus APP



### AC Cable\*1

- EU standard integral die casting
- High temperature resistance, anti-oxidation material
- With European standard plug

# System Structure

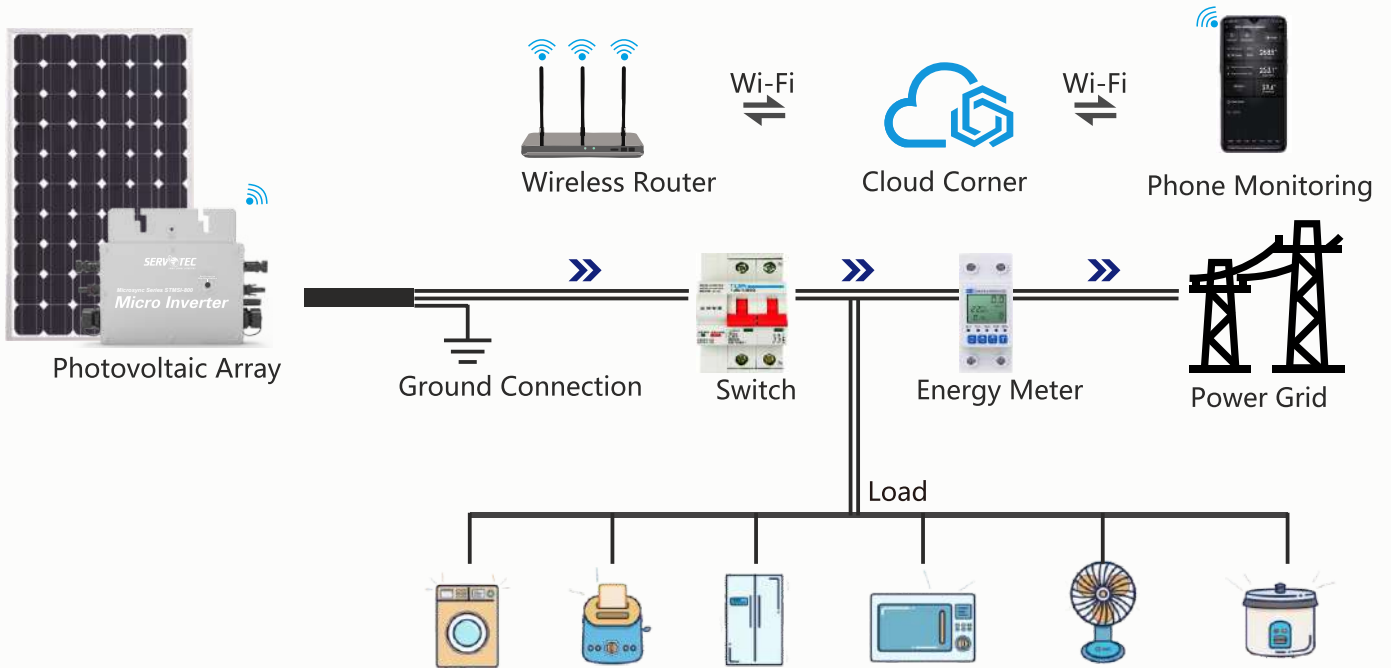

**⚠** To prevent the risk of electric shock, it is recommended that the installation and commissioning of the system be carried out by certified personnel with professional knowledge.

# APP Details Display

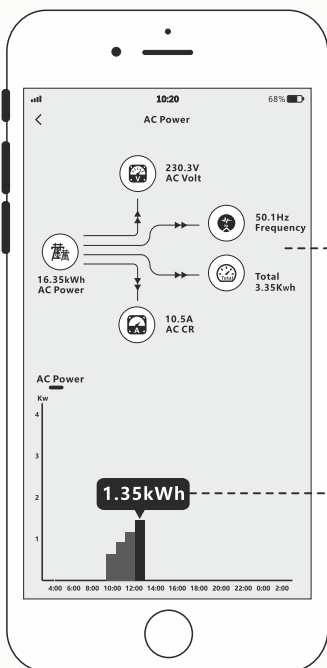

AC Output Power details

AC Power Curve Diagram

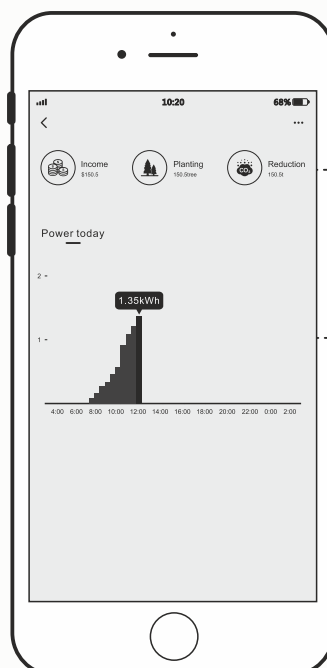

Energy conservation and environmental protection data statistics

Current electricity display

# APP Main Function Menu

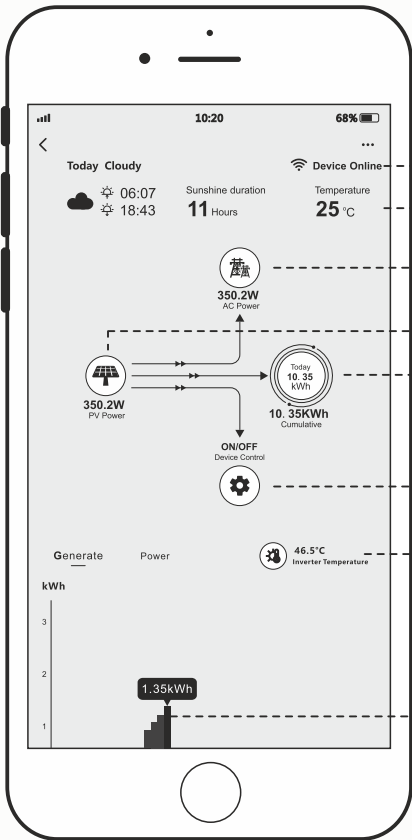

- Device Online status display
- Current weather conditions
- AC Power (Click to enter details)
- PV Power (Click to enter details)
- Current electricity (Click to enter details)
- Device Control (Click to View Detailed Function Display)
- Inverter Temperature
- Power & Electricity curve display

# APP Function Control

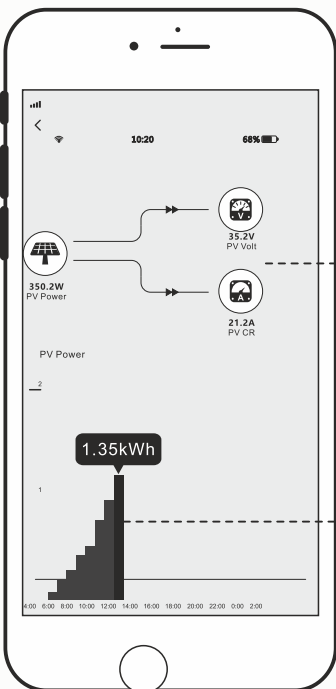

- PV Input Power details
- PV Power Curve Diagram

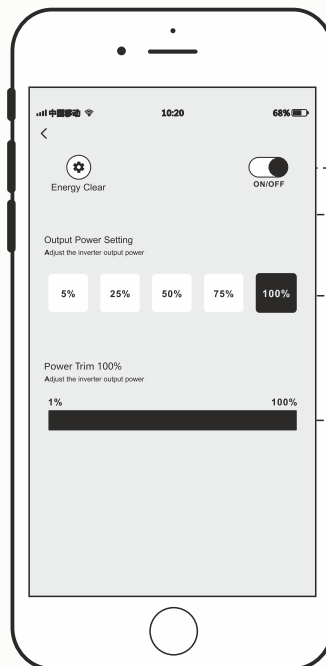

- On/Off switch control
- Electricity data reset
- Output Power Adjustment
- Output Power Precise Adjustment

# Microsync Series

Handshake connection installation mode intelligent microinverter.

## Product Features



Microsync Series PV micro inverters can adapt to a variety of harsh environments, suitable for residential, public applications and factories and ground power stations.



Using advanced forward inverter grid-connected technology, higher output efficiency, conversion efficiency up to 94%.



IP65 waterproof rating can effectively prevent the erosion of rain on the surface



Excellent low light automatic locking function (APL) makes your PV power plant more efficient (morning, evening, rainy day)



High performance Maximum Power Point tracking (MPPT) function, can better track the change of solar luminosity and control different output power, effectively capture and collect sunlight

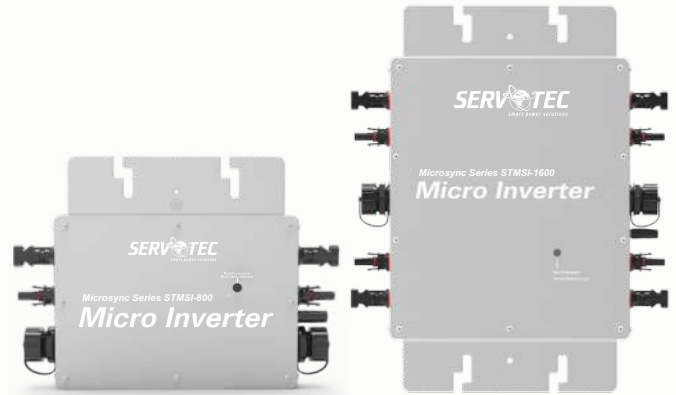

## Professional Core Tech.

- Unique inverter processing core
- High performance max. power point capture (MPPT)
- Powerful power automatic locking (APL)

## First Class Warranty

- 5 years free product warranty
- 25 years limited warranty
- Commitment to lifetime service

## Intelligent life monitoring platform communication mode

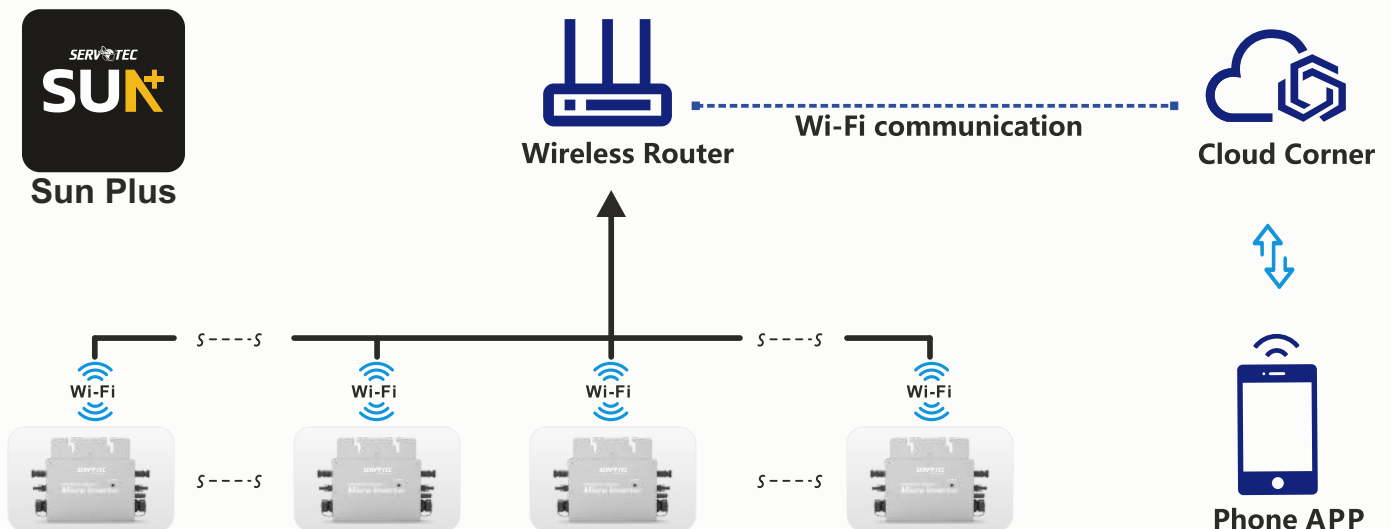

# Ongrid Micro Inverter

## Microsync STMSI-800



## Professional Core Technology

- Unique inverter processing core
- High performance Maximum Power Point
- Capture (MPPT) Powerful automatic power locking (APL)

## First Class Warranty

- 5 years free product warranty
- 25 years Limited warranty
- Promises lifetime service



**Microsync STMSI-800**  
(1 Driven 2)

## Features Description

- ⊙ Open circuit voltage range: 30-60VDC
- ⊙ Output voltage range: 85-160VAC/180-265VAC
- ⊙ Output frequency range: 48-51Hz/58-61Hz
- ⊙ Maximum output power: 800WATT
- ⊙ Output waveform type: pure sine wave
- ⊙ Maximum power point tracking (MPPT)
- ⊙ High frequency, micro, intelligent monitoring system
- ⊙ Gross weight: 2.8KG
- ⊙ Size: 283mm×200mm×41.6mm
- ⊙ Communication: Wi-Fi
- ⊙ Waterproof rating: IP65

## PV Microinverter Functions & Features

---

- High performance automatic Power Point Tracking (MPPT)
- Reverse power transmission
- Intelligent monitoring and management
- The input and output are completely isolated to ensure power
- Safety and high reliability
- Full digital control
- Simplified maintenance (user maintenance)
- Low operation and maintenance cost
- Flexible installation

### Microsync STMSI-800

Built-in high-performance Maximum Power Point Tracking (Maximum Power Point Tracking) function, can better track the change of the sun's luminosity and control different output power, effectively capture and collect sunlight. The power transmission adopts reverse AC power transmission technology, which is one of our patented technologies. The power output of the inverter can give priority to the use of the load, and the unused power is transmitted to the grid in the reverse direction. The power transmission rate can reach more than 99% by efficiently using the power generated by the inverter. Built-in Wi-Fi & Bluetooth dual-mode communication module, just connect to the home wireless network can easily achieve data transmission, with the “Sun Plus” Internet of Things APP, you can control and view all kinds of data.

# Ongrid Micro Inverter Microsync STMSI-1600



## Professional Core Technology

---

- Unique inverter processing core
- High performance Maximum Power Point
- Capture (MPPT) Powerful automatic power locking (APL)

## First Class Warranty

---

- 5 years free product warranty
- 25 years Limited warranty
- Promises lifetime service



**Microsync STMSI-1600**  
(1 Driven 4)

## Features Description

- ⊙ Open circuit voltage range: 30-60VDC
- ⊙ Output voltage range: 85-160VAC/180-265VAC
- ⊙ Output frequency range: 48-51Hz/58-61Hz
- ⊙ Maximum output power: 1600WATT
- ⊙ Output waveform type: pure sine wave
- ⊙ Maximum power point tracking (MPPT)
- ⊙ High frequency, micro, intelligent monitoring system
- ⊙ Gross weight: 4KG
- ⊙ Size: 370mm×300mm×41.6mm
- ⊙ Communication: Wi-Fi
- ⊙ Waterproof rating: IP65

## PV Microinverter Functions & Features

---

- High performance automatic Power Point Tracking (MPPT)
- Reverse power transmission
- Intelligent monitoring and management
- The input and output are completely isolated to ensure power
- Safety and high reliability
- Full digital control
- Simplified maintenance (user maintenance)
- Low operation and maintenance cost
- Flexible installation

### Microsync STMSI-1600

**Built-in high-performance Maximum Power Point Tracking (Maximum Power Point Tracking) function, can better track the change of the sun's luminosity and control different output power, effectively capture and collect sunlight. The power transmission adopts reverse AC power transmission technology, which is one of our patented technologies. The power output of the inverter can give priority to the use of the load, and the unused power is transmitted to the grid in the reverse direction. The power transmission rate can reach more than 99% by efficiently using the power generated by the inverter. Built-in Wi-Fi & Bluetooth dual-mode communication module, just connect to the home wireless network can easily achieve data transmission, with the “Sun Plus” Internet of Things APP, you can control and view all kinds of data.**



**INDIA'S**  
**TRUSTED**



रहो रेशन  
बिना टेंशन...

## Servotech Renewable Power System Ltd.

**Corporate Office :** 806, 8th Floor, Crown Heights, Sector-10, Rohini, New Delhi - 110085

**Ph: 011-41183116, +91 9818680033**

 **+91 9311313734**

**Email:** [servotech@servotechindia.com](mailto:servotech@servotechindia.com)

**Website:** [www.servotech.in](http://www.servotech.in)

**Reg. Add. & Kundli Plant:** Khata No. 1970, Khewat No. 1672, Khasra No. 21/20/2/2, Revenue Estate, Kundli, P.S.Rai, Sonipat, Haryana - 131029

**Safabad Plant:** Killa No. 14/6/1/2 (0-3), 6/2/3 (5-13) Village-Safabad, Pana Paposhian, Rai, Sonipat, Haryana - 131029

**Warehouse:** Khasra No. 8/5, 6, 14/2, 15/1, 16/2 Min & 17, Jakhali Road, Jhundpur, Sonipat, Haryana - 131021

